

**JANUARY 1996**

## **PROVINCIAL EXAMINATION**

---

**MINISTRY OF EDUCATION**

# **PHYSICS 12**

### **GENERAL INSTRUCTIONS**

1. Insert the stickers with your Student I.D. Number (PEN) in the allotted space above. **Under no circumstance is your name or identification, other than your Student I.D. Number, to appear on this paper.**
2. Take the separate Answer Sheet and follow the directions on its front page.
3. Be sure you have an **HB pencil** and an eraser for completing your Answer Sheet. Follow the directions on the Answer Sheet when answering multiple-choice questions.
4. For each of the written-response questions, write your answer in the space provided.
5. When instructed to open this booklet, **check the numbering of the pages** to ensure that they are numbered in sequence from page one to the last page, which is identified by

**END OF EXAMINATION**.

6. At the end of the examination, place your Answer Sheet inside the front cover of this booklet and return the booklet and your Answer Sheet to the supervisor.

**THIS PAGE INTENTIONALLY BLANK**

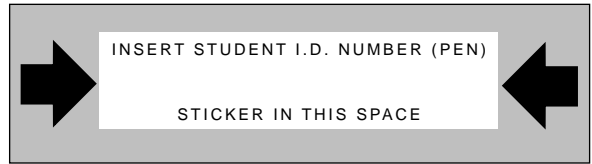

\_\_\_\_\_ - \_\_\_\_\_

**PHYSICS 12 JANUARY 1996 PROVINCIAL**

**Course Code = PH Examination Type = P**

1. \_\_\_\_\_  
(7)

5. \_\_\_\_\_  
(7)

2. \_\_\_\_\_  
(7)

6. \_\_\_\_\_  
(9)

3. \_\_\_\_\_  
(7)

7. \_\_\_\_\_  
(4)

4. \_\_\_\_\_  
(7)

Score **only one** of the following sections.

**Section I**

**Section II**

**Section III**

8. \_\_\_\_\_  
(3)

11. \_\_\_\_\_  
(3)

14. \_\_\_\_\_  
(3)

9. \_\_\_\_\_  
(4)

**or**

12. \_\_\_\_\_  
(4)

**or**

15. \_\_\_\_\_  
(4)

10. \_\_\_\_\_  
(5)

13. \_\_\_\_\_  
(5)

16. \_\_\_\_\_  
(5)

**THIS PAGE INTENTIONALLY BLANK**

## PHYSICS 12 PROVINCIAL EXAMINATION

	Value	Suggested Time
1. This examination consists of <b>three</b> parts:		
PART A: 30 multiple-choice questions worth two marks each	60	60
PART B: 7 written-response questions	48	48
PART C: Elected topics consisting of only written-response questions. Answer <b>only one</b> section.	12	12
	<b>Total: 120 marks</b>	<b>120 minutes</b>

- The last **three** pages inside the back cover contain the **Data Table, Trigonometric and Other Equations, Equations, and Rough Work for Multiple-Choice**. These pages may be detached for convenient reference prior to writing this examination.
- Rough-work space has been incorporated into the space allowed for answering each written-response question. You may not need all of the space provided to answer each question.
- An approved scientific calculator is essential for the examination. The calculator must be a hand-held device designed **only** for mathematical computations such as logarithmic and trigonometric functions. It **can be** programmable, but **must not** contain any graphing capabilities. You **must not** bring into the examination room any devices to support calculators such as manuals, printed or electronic cards, printers, memory expansion chips or cards, or keyboards.
- You are permitted to use rulers, compasses, and protractors.
- Final answers must include appropriate **units**.
  - Marks will not be deducted for answers expressed to **two** or **three** significant figures.
  - In this examination, the zero in a number such as 30 shall be considered to be a significant zero.
- You are expected to communicate your knowledge and understanding of physics principles in a clear and logical manner. Partial marks will be awarded for steps and assumptions leading to a solution. Full marks will **not** be awarded for providing **only** a final answer.

If you are unable to determine the value of a quantity required in order to proceed, you may assume a reasonable value and continue toward the solution. Such a solution, however, may not be eligible for full marks.

- You have **two hours** to complete this examination.

**THIS PAGE INTENTIONALLY BLANK**

**PART A: MULTIPLE-CHOICE**

**Value: 60 marks (2 marks per question)**

**Suggested Time: 60 minutes**

**INSTRUCTIONS:** For each question, select the **best** answer and record your choice on the Answer Sheet provided. Using an HB pencil, completely fill in the circle that has the letter corresponding to your answer.

1. Which of the following graphs represents the horizontal velocity component ( $v_x$ ) versus time for a projectile thrown horizontally off a cliff? (Ignore air resistance.)

A.

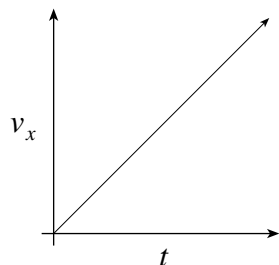

B.

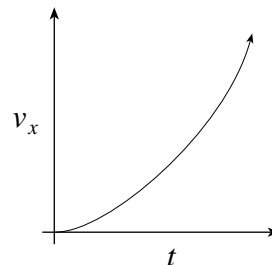

C.

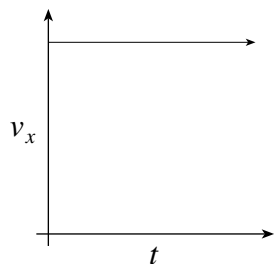

D.

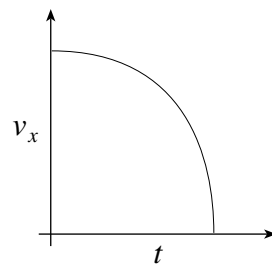

2. A skier accelerates uniformly from 5.2 m/s to 12.8 m/s at  $0.85 \text{ m/s}^2$ . Find the distance she travels.

- A. 7.7 m
- B. 8.9 m
- C. 11 m
- D. 80 m

3. The diagram below shows a cart being pulled up a frictionless slope by a rope.

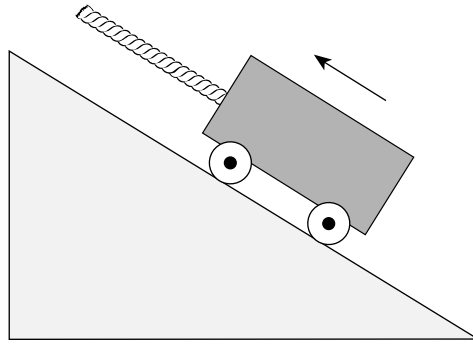

Which of the following **best** represents the free body diagram for the cart?

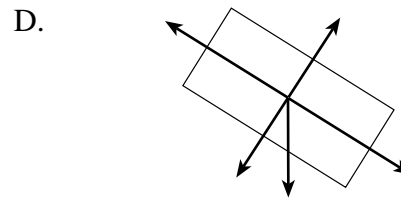
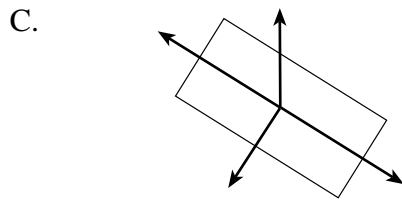
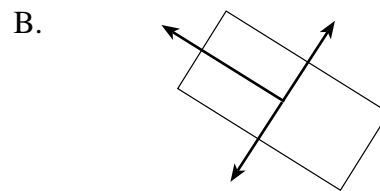
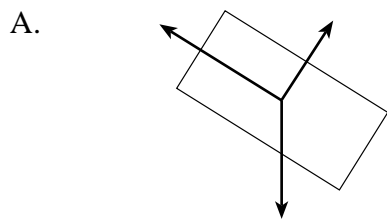

4. A projectile is launched over level ground at 35 m/s at an angle of  $40^\circ$  above the horizontal. What is the projectile's time of flight?
- A. 2.3 s
  - B. 4.6 s
  - C. 5.5 s
  - D. 7.1 s



5. A massless, frictionless pulley is suspended by a rope. When the masses are allowed to accelerate, the tension in the string joining them is 28 N at **X**. What will the tension be at **Y** and at **Z**?

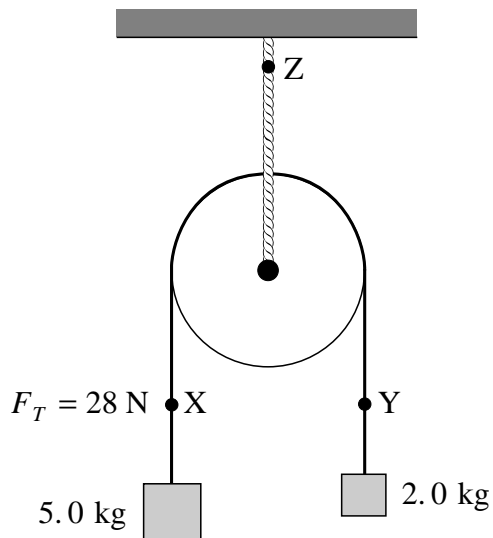

	TENSION AT Y	TENSION AT Z
A.	20 N	48 N
B.	20 N	69 N
C.	28 N	56 N
D.	28 N	69 N

6. Which expression is equal to the net force on an object?

- A.  $\frac{\Delta p}{\Delta t}$
- B.  $\frac{W}{\Delta t}$
- C.  $m\Delta v$
- D.  $\Delta E$

7. The diagram shows a collision between a 4.0 kg toy car and a stationary 8.0 kg toy truck. After the collision, the car bounces back at 1.0 m/s while the truck goes forward at 2.0 m/s. **Based on these values**, are momentum and kinetic energy conserved?

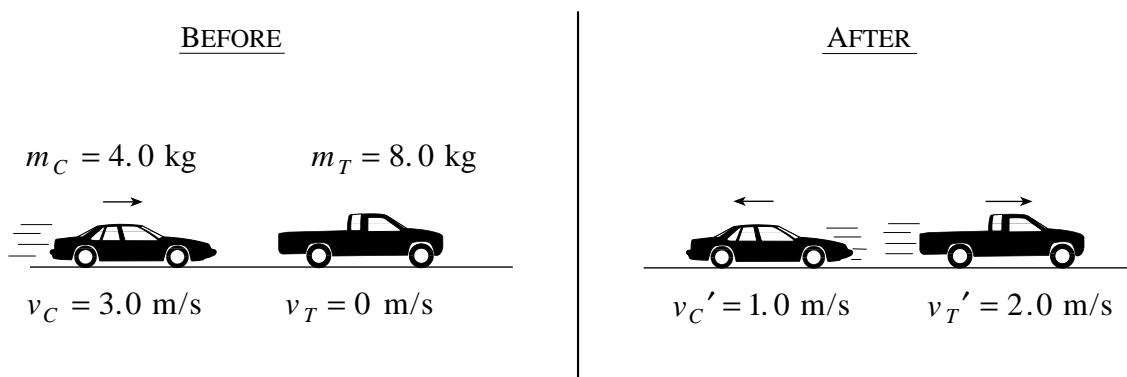

	MOMENTUM	KINETIC ENERGY
A.	Conserved	Conserved
B.	Conserved	Not Conserved
C.	Not Conserved	Conserved
D.	Not Conserved	Not Conserved

8. A uniform 18 kg beam hinged at **P** is held horizontal by a vertical string that can withstand a maximum tension of 350 N. A 5.0 kg mass is suspended from the end of the beam as shown.

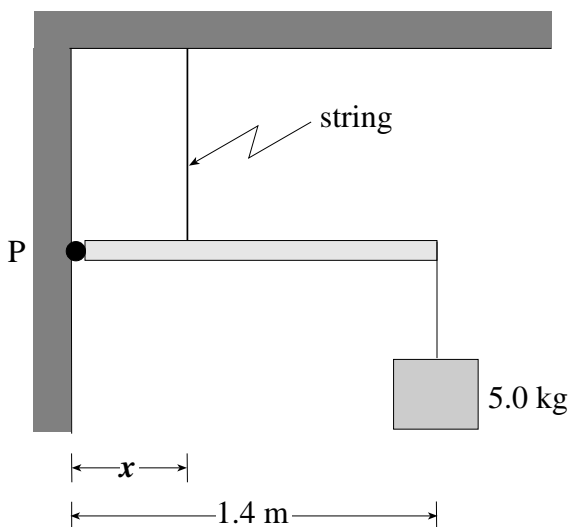

At what minimum distance,  $x$ , can the string be attached without breaking?

- A. 0.16 m
- B. 0.20 m
- C. 0.55 m
- D. 0.70 m

9. The diagram shows the forces acting on a massless ladder resting on the floor and a frictionless slope.

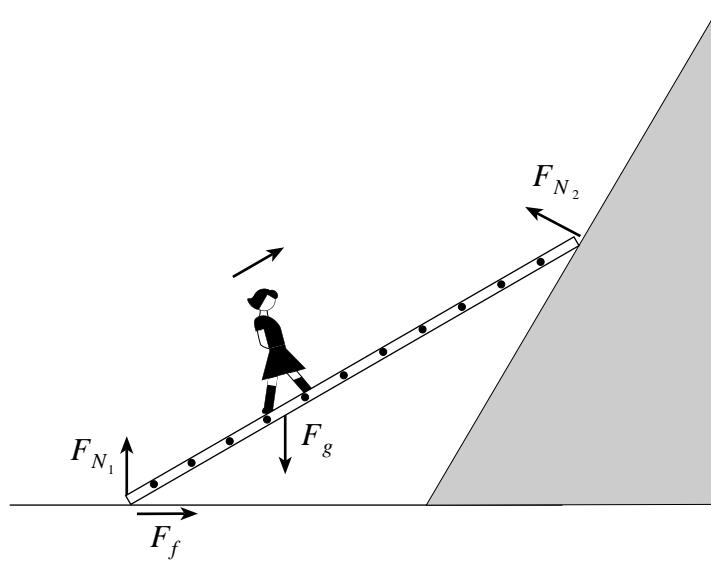

As a person walks up the stationary ladder, what happens to the magnitude of the forces  $F_{N_1}$  and  $F_{N_2}$ ?

	MAGNITUDE OF $F_{N_1}$	MAGNITUDE OF $F_{N_2}$
A.	Decreases	Decreases
B.	Decreases	Increases
C.	Increases	Decreases
D.	Increases	Increases

10. An object moves at a constant speed along a circular path as shown.

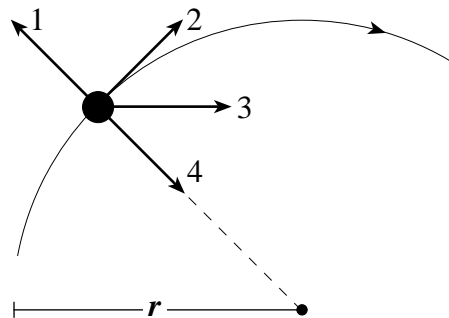

Which vector represents the velocity of the object at this particular point on the path?

- A. 1  
 B. 2  
 C. 3  
 D. 4

11. What is the centripetal acceleration of a satellite having an orbital period of  $6.1 \times 10^3$  s while in a circular orbit of radius  $7.2 \times 10^6$  m?
- A.  $0 \text{ m/s}^2$
  - B.  $5.2 \text{ m/s}^2$
  - C.  $7.6 \text{ m/s}^2$
  - D.  $9.8 \text{ m/s}^2$
12. Two satellites, **X** and **Y**, are placed in orbit around a planet. Satellite **X** has a period of revolution of  $3.6 \times 10^5$  s and an orbital radius of  $7.5 \times 10^8$  m. If the orbital radius of satellite **Y** is  $3.0 \times 10^9$  m, what is its orbital period?
- A.  $9.1 \times 10^5$  s
  - B.  $1.4 \times 10^6$  s
  - C.  $2.9 \times 10^6$  s
  - D.  $5.2 \times 10^7$  s
13. What is the escape velocity for an object on the surface of a  $1.9 \times 10^{27}$  kg planet of radius  $7.2 \times 10^7$  m?
- A.  $7.0 \text{ m/s}$
  - B.  $3.8 \times 10^4 \text{ m/s}$
  - C.  $4.2 \times 10^4 \text{ m/s}$
  - D.  $5.9 \times 10^4 \text{ m/s}$

14. A bus of weight  $F_g$  is moving at a constant speed over a hill and dip that have the same radius of curvature.

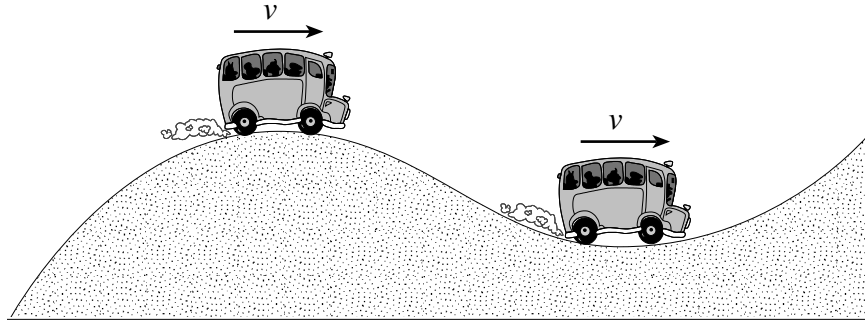

When the bus is passing over the crest of the hill, the road exerts a normal force on the bus equal to three quarters of the bus's weight ( $\frac{3}{4} F_g$ ). What is the normal force the road exerts on the bus when the bus is passing through the bottom of the dip?

- A.  $\frac{1}{4} F_g$   
 B.  $\frac{3}{4} F_g$   
 C.  $\frac{5}{4} F_g$   
 D.  $\frac{7}{4} F_g$
15. Which of the following diagrams shows the electric field in the region of two equal but opposite point charges?

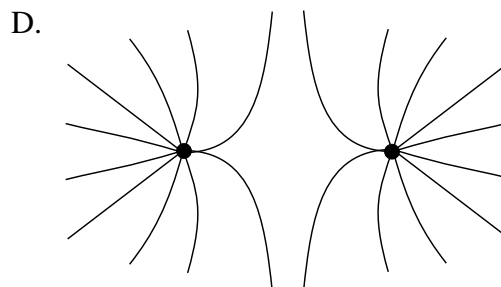
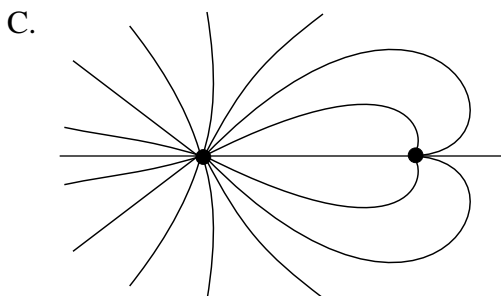
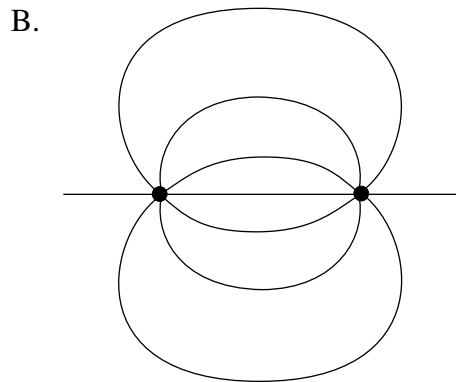
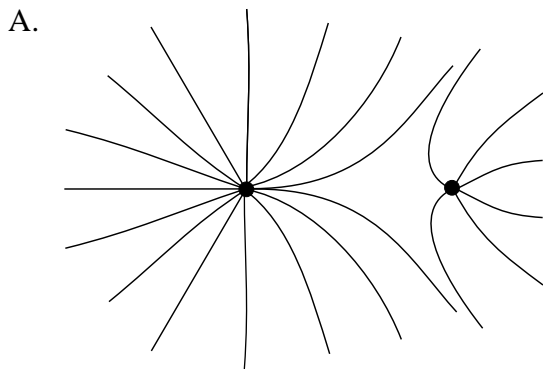

16. An electron experiences an electric force of  $1.8 \times 10^{-11} \text{ N}$  at a distance of  $5.0 \times 10^{-9} \text{ m}$  from the nucleus of an ion. The electron is moved farther away, to a distance of  $2.0 \times 10^{-8} \text{ m}$  from the ion. What is the new electric force on the electron?

- A.  $1.1 \times 10^{-12} \text{ N}$
- B.  $4.5 \times 10^{-12} \text{ N}$
- C.  $7.2 \times 10^{-11} \text{ N}$
- D.  $2.9 \times 10^{-10} \text{ N}$

17. What is the magnitude of the electric field at point **P** due to the two fixed charges as shown?

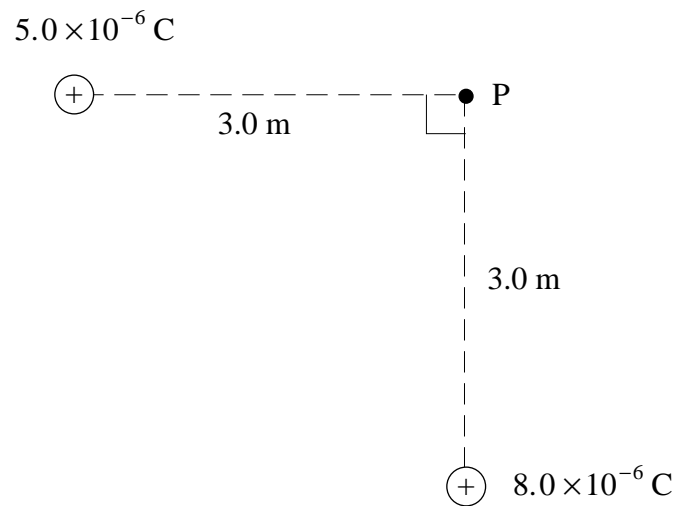

- A.  $3.0 \times 10^3 \text{ N/C}$
- B.  $9.4 \times 10^3 \text{ N/C}$
- C.  $1.3 \times 10^4 \text{ N/C}$
- D.  $3.9 \times 10^4 \text{ N/C}$

18. An electron is travelling in an electric field as shown.

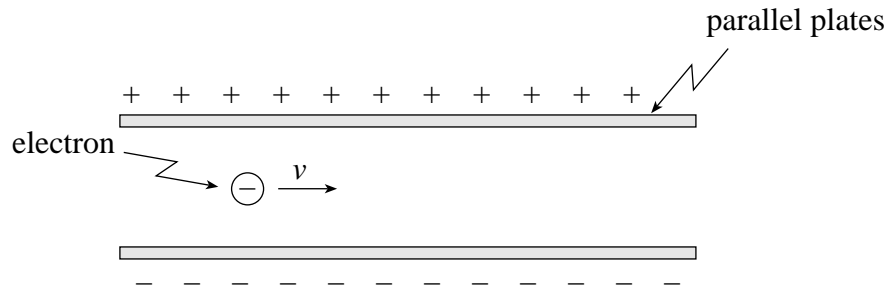

Describe the electrostatic force acting on the electron while in the field.

	MAGNITUDE OF FORCE	DIRECTION OF FORCE
A.	Changing	Upward
B.	Changing	Downward
C.	Constant	Upward
D.	Constant	Downward

19. A proton initially at rest is accelerated between parallel plates through a potential difference of 300 V.

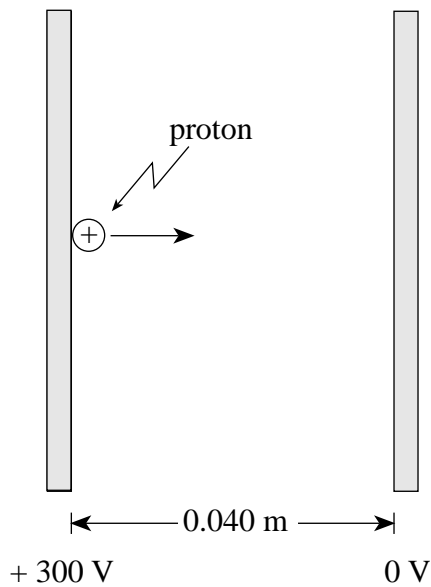

What is the maximum speed attained by the proton?

- A.  $7.5 \times 10^3$  m/s
- B.  $1.7 \times 10^5$  m/s
- C.  $2.4 \times 10^5$  m/s
- D.  $1.2 \times 10^6$  m/s

20. Which of the following relationships correctly applies to the circuit shown below?

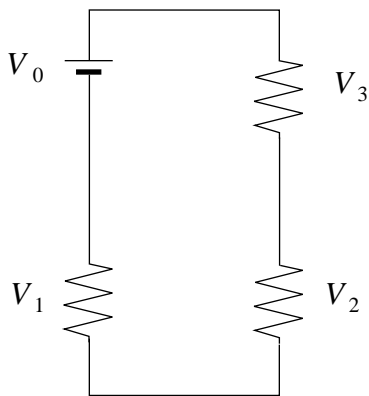

- A.  $V_0 = V_1 + V_2 + V_3$
- B.  $V_0 + V_1 = V_2 + V_3$
- C.  $V_0 = V_1 = V_2 = V_3$
- D.  $\frac{1}{V_0} = \frac{1}{V_1} + \frac{1}{V_2} + \frac{1}{V_3}$

21. A 9.0 V battery was recharged with a current of 1.2 A in  $1.8 \times 10^4$  s. How much charge was transferred during that time?

- A.  $1.1 \times 10^1$  C
- B.  $2.2 \times 10^4$  C
- C.  $1.6 \times 10^5$  C
- D.  $1.9 \times 10^5$  C

22. In the following circuit, what current is drawn from the battery?

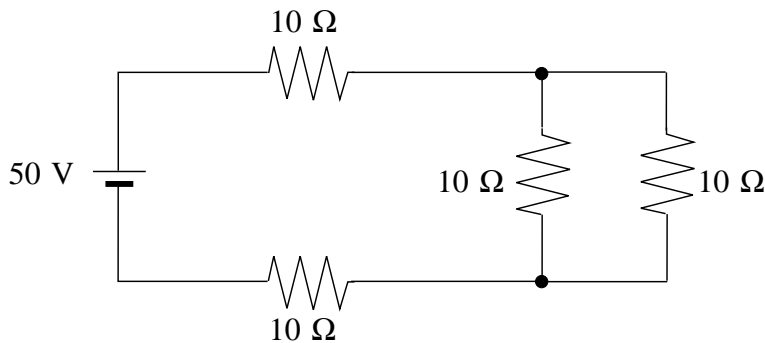

- A. 1.3 A
- B. 1.7 A
- C. 2.0 A
- D. 5.0 A



23. In the following circuit, what is the power loss in the battery?

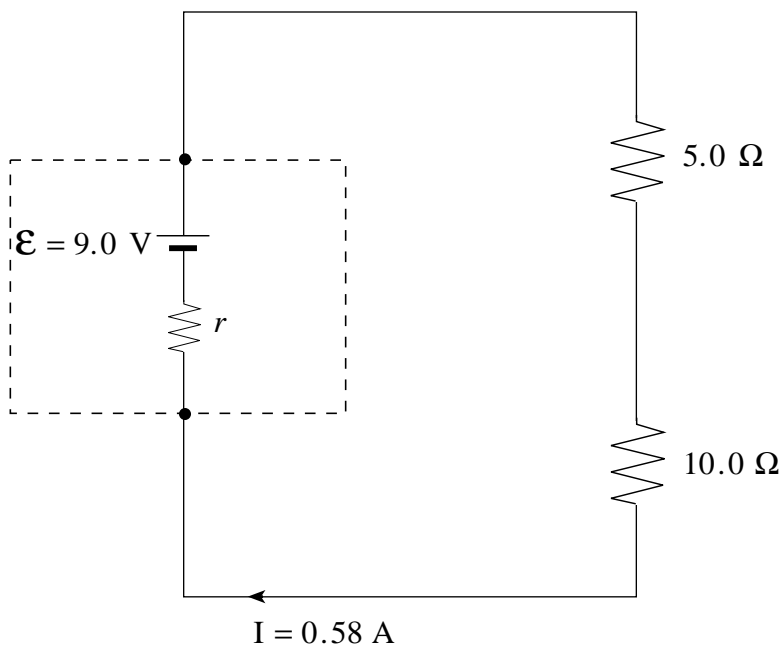

- A. 0 W
- B. 0.17 W
- C. 5.0 W
- D. 5.2 W

24. Which of the following diagrams shows the magnetic field produced by a long current-carrying wire?

A.

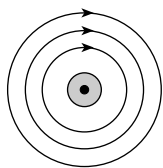

B.

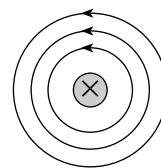

C.

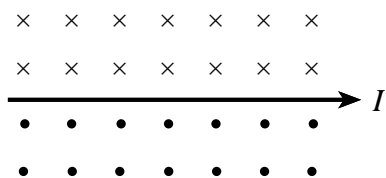

D.

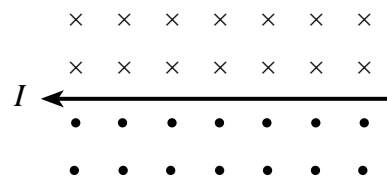

25. The diagram below shows an electron travelling to the left in a magnetic field.

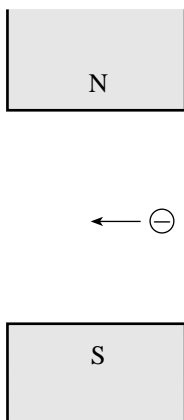

In which direction will the electron be deflected?

- A. into the page
  - B. out of the page
  - C. towards the north pole
  - D. towards the south pole
26. A doubly-ionized atom ( $Q = 2e$ ) with a mass of  $6.8 \times 10^{-27}$  kg enters a 3.0 T magnetic field with a speed of  $5.0 \times 10^7$  m/s. What is the radius of the circular path of the atom?
- A. 0.35 m
  - B. 0.71 m
  - C. 1.4 m
  - D. 2.8 m
27. A wire is in a magnetic field as shown.

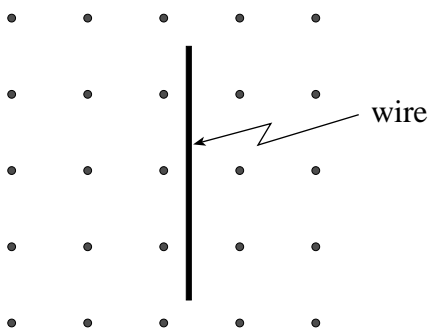

In which direction could the wire be moved to induce an emf across the length of the wire?

- A. to the left
- B. up the page
- C. into the page
- D. down the page

28. An emf is induced in a coil if the magnetic flux through the coil is
- zero.
  - changing.
  - constant and large.
  - constant and small.
29. A coil of wire contains 55 loops. The coil is rotated such that the flux changes from  $2.0 \times 10^{-4}$  Wb to  $8.0 \times 10^{-4}$  Wb in  $1.5 \times 10^{-2}$  s. What is the average induced emf?
- 1.1 V
  - 1.8 V
  - 2.2 V
  - 3.7 V
30. A door bell transformer has 900 primary windings and 60 secondary windings. The secondary current is 0.30 A. What is the primary current and what is the type of transformer?

	PRIMARY CURRENT (A)	TRANSFORMER TYPE
A.	0.020	Step-Up
B.	0.020	Step-Down
C.	4.5	Step-Up
D.	4.5	Step-Down

**This is the end of the multiple-choice section.  
Answer the remaining questions directly in this examination booklet.**

**THIS PAGE INTENTIONALLY BLANK**

## PART B: WRITTEN-RESPONSE

Value: 48 marks

Suggested Time: 48 minutes

### INSTRUCTIONS:

1. Rough-work space has been incorporated into the space allowed for answering each written-response question. You may not need all of the space provided to answer each question.
2.
  - a) Final answers must include appropriate **units**.
  - b) Marks will not be deducted for answers expressed to **two** or **three** significant figures.
  - c) In this examination, the zero in a number such as 30 shall be considered to be a significant zero.
3. You are expected to communicate your knowledge and understanding of physics principles in a clear and logical manner. If you are unable to determine the value of a quantity required in order to proceed, you may assume a reasonable value and continue toward the solution. Partial marks will be awarded for steps and assumptions leading to a solution. Such a solution, however, may not be eligible for full marks.

**Full marks will NOT be given for the final answer only.**

1. A boat which can travel at  $5.6 \text{ m/s}$  in still water heads due east across a river from a dock at **X**. The boat's resultant path is  $32^\circ$  south of east.

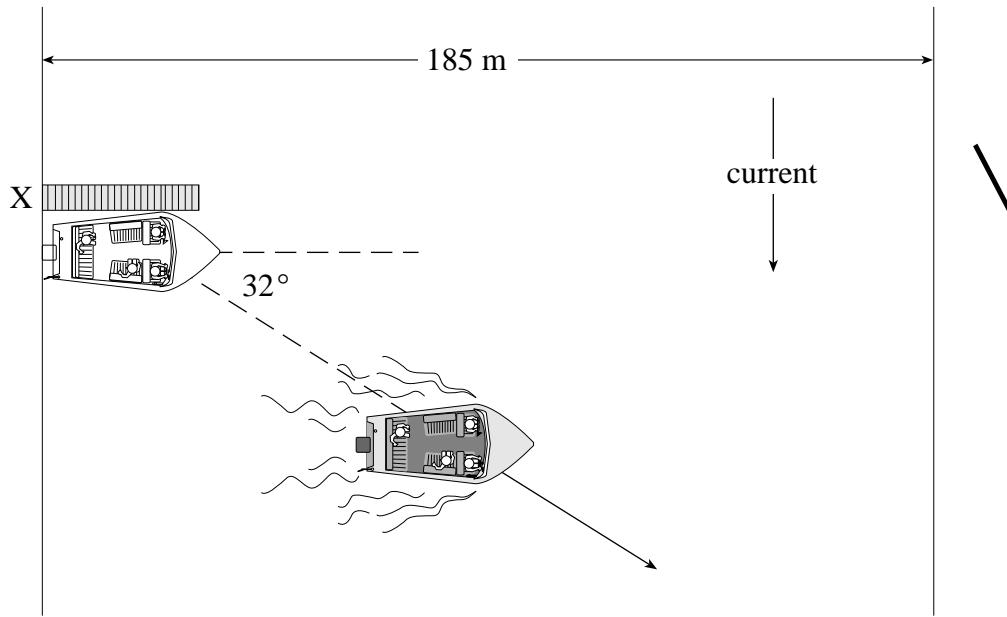

a) What is the speed of the current?

**(5 marks)**

b) How long will it take the boat to reach the far shore if the river is 185 m wide? **(2 marks)**

ANSWER:	Score for Question 1:
a) speed: _____	1. _____
b) time: _____	(7)

**OVER**

2. As a 62 kg skier descends from **A** to **B** her velocity increases from 8.5 m/s to 23.3 m/s. Friction between **A** and **B** generates 8 700 J of heat energy. Through what vertical height,  $h$ , did the skier descend? (7 marks)

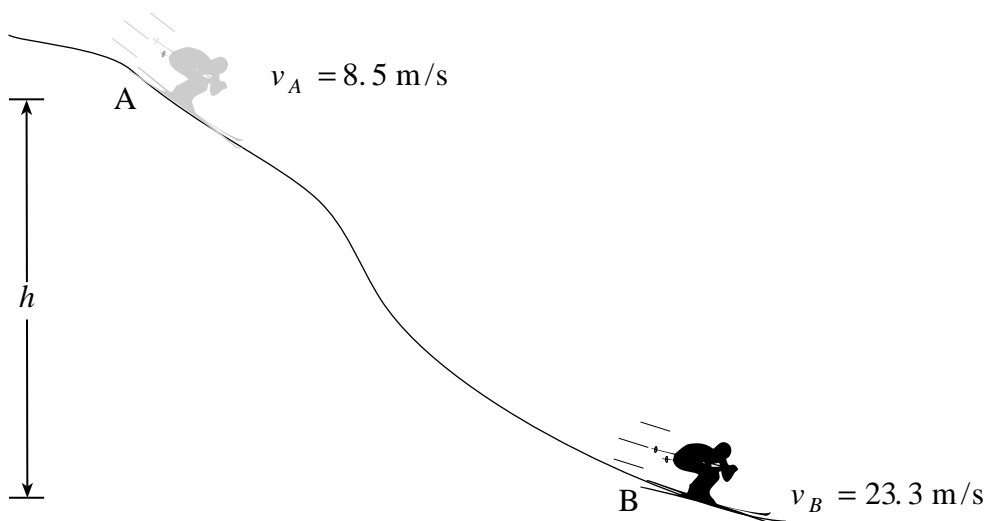



ANSWER:  vertical height: _____	Score for Question 2:  2. _____ (7)
---------------------------------------	---

**OVER**

3. A circus performer walks across a wire stretched between two vertical posts. When the performer stands at position **X** as shown below, the tension in the short length of wire attached to post **B** is  $1.8 \times 10^3$  N.

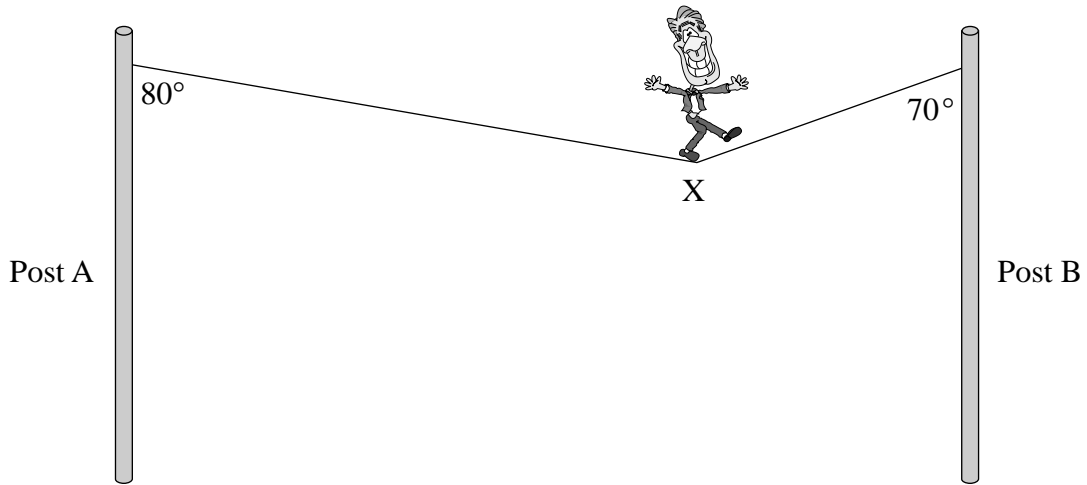

- a) Draw and label a free body diagram showing the forces acting at position **X**. **(2 marks)**

b) What is the mass of the circus performer?

**(5 marks)**

ANSWER:	Score for Question 3:
b) mass: _____	3. _____ (7)

**OVER**

4. An astronaut stands on the surface of a planet of radius  $2.6 \times 10^6$  m. An object dropped from the astronaut's hand accelerates at  $3.2 \text{ m/s}^2$ .

a) What is the mass of this planet?

**(5 marks)**

b) What is the force of gravity on an 18 kg mass located on the surface of this planet? (2 marks)

ANSWER: a) mass of planet: _____ b) force of gravity: _____	Score for Question 4: 4. _____ (7)
---	---

**OVER**

5. In the circuit shown below, determine the current through the  $5.0\ \Omega$  resistor.

**(7 marks)**

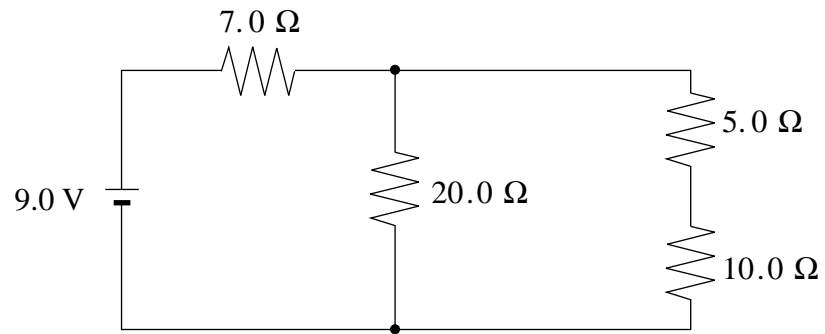

ANSWER:	Score for Question 5:
current: _____	5. _____ (7)

**OVER**

6. a) A 16.0 V power supply is used to run a dc motor. When the motor is jammed so that it cannot turn, it draws a current of 12.0 A. What is the back or counter emf when the motor runs freely, drawing a current of 2.50 A? **(5 marks)**



- b) Using principles of physics, explain why the motor draws a much higher current when jammed than when running freely. **(4 marks)**

---

---

---

---

---

---

---

---

---

---

ANSWER:

a) back emf: \_\_\_\_\_

Score for  
Question 6:

6. \_\_\_\_\_  
(9)

**OVER**

7. Two students throw identical tennis balls towards a building at the same speed. One ball strikes the wall, bouncing back at half its original speed. The other ball smashes a window and continues in the same direction at half its original speed. Did the two tennis balls experience the same impulse when in contact with the wall and the window? Justify your answer using principles of physics. **(4 marks)**

---

---

---

---

---

---

---

---

Score for  
Question 7:

7. \_\_\_\_\_  
(4)

**This is the end of written-response Part B.**

## PART C: ELECTED TOPICS

Value: 12 marks

Suggested Time: 12 minutes

### INSTRUCTIONS

1. Choose **only one** section from the three sections in this part of the examination.

SECTION I: Quantum Mechanics (p. 30 to 33)

**or**

SECTION II: Fluid Theory (p. 34 to 37)

**or**

SECTION III: AC Circuitry and Electronics (p. 38 to 41)

2. If you answer questions in more than one section, only the answers in the first section chosen will be marked.
3. Answer **all** of the questions in the section that you choose. **Write your answers in the space provided in this booklet.**
4. Rough-work space has been incorporated into the space allowed for answering each question. You may not need all of the space provided to answer each question.
5.
  - a) Final answers must include appropriate **units**.
  - b) Marks will not be deducted for answers expressed to **two** or **three** significant figures.
  - c) In this examination, the zero in a number such as 30 shall be considered to be a significant zero.
6. Since partial marks will be awarded for a partial solution, it is important that you provide a clear indication of the steps leading to your answer.

**Full marks will NOT be given for the final answer only.**

I have selected SECTION \_\_\_\_\_.

**OVER**

## SECTION I: Quantum Mechanics

1. The electron in a singly-ionized helium atom (2 protons and 2 neutrons) has  $-2.18 \text{ eV}$  of energy. What is the quantum number for this energy state? **(3 marks)**

ANSWER:  quantum number: _____	Score for Question 1:  8. _____ (3)
--------------------------------------	---

**SECTION I: Continued**

2. Incident photons strike a surface with a work function of  $2.2 \text{ eV}$ . The maximum kinetic energy of the emitted electrons is  $8.0 \times 10^{-19} \text{ J}$ . What is the wavelength of the incident photons? **(4 marks)**

ANSWER:  wavelength: _____	Score for Question 2:  9. _____ (4)
----------------------------------	---

**SECTION I: Continued**

3. What is the de Broglie wavelength of a proton with a kinetic energy of  $5\,000\text{ eV}$ ? **(5 marks)**

ANSWER:

wavelength: \_\_\_\_\_

Score for  
Question 3:

10. \_\_\_\_\_  
(5)

**END OF SECTION I: Quantum Mechanics**

**OVER**

## SECTION II: Fluid Theory

1. At what temperature is the average kinetic energy of an oxygen molecule  $6.40 \times 10^{-21}$  J?  
(3 marks)

ANSWER:	Score for Question 1:
temperature: _____	11. _____ (3)



**SECTION II: Continued**

2. Air is travelling past an aircraft wing such that the speed is 42 m/s over the top surface and 32 m/s past the bottom surface. What is the difference in pressure for the two surfaces of this wing? **(4 marks)**

ANSWER:  difference in pressure: _____	Score for Question 2:  12. _____ (4)
--	--

**OVER**

**SECTION II: Continued**

3. A block of ice floats on fresh water. What minimum volume must the block of ice have in order for a 73 kg man to be able to stand on it without submerging the block? The density of ice is  $9.2 \times 10^2 \text{ kg/m}^3$ . **(5 marks)**

ANSWER:

minimum volume: \_\_\_\_\_

Score for  
Question 3:

13.  $\frac{\quad}{(5)}$

**END OF SECTION II: Fluid Theory**

**OVER**

### SECTION III: AC Circuitry and Electronics

1. A capacitor connected across a potential difference of 16 V has a charge of  $3.8 \times 10^{-5}$  C.  
What is its capacitance? **(3 marks)**

ANSWER:	Score for Question 1:
capacitance: _____	14. _____ (3)

**SECTION III: Continued**

2. The graph below shows the current-voltage characteristics for a certain diode.

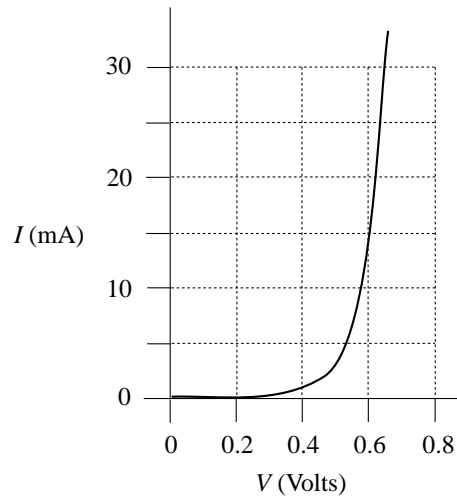

The diode is to conduct 15 mA when connected to a 9.0 V source. What resistance must be connected in series with the diode? **(4 marks)**

ANSWER:	Score for Question 2:
resistance: _____	15. _____ (4)

**OVER**

**SECTION III: Continued**

3. What is the voltage drop across the inductor in the circuit below?

**(5 marks)**

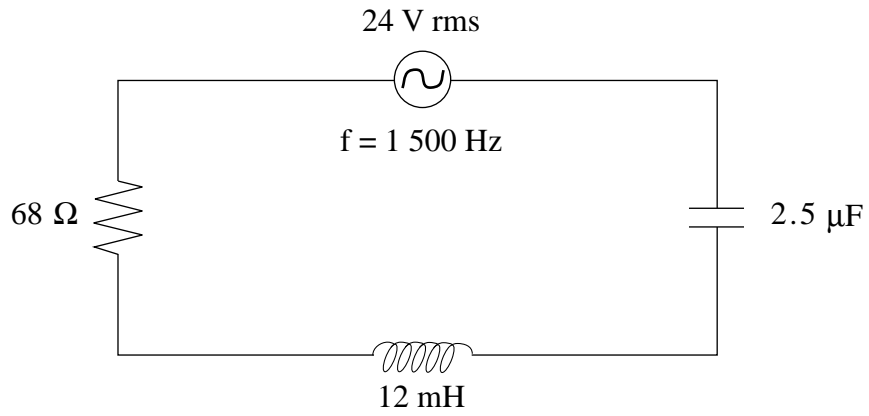

ANSWER:

voltage drop: \_\_\_\_\_

Score for  
Question 3:

16.         
(5)

**END OF SECTION III: AC Circuitry and Electronics**

**END OF EXAMINATION**

**THIS PAGE INTENTIONALLY BLANK**



## DATA TABLE

Gravitational constant .....	$G = 6.67 \times 10^{-11} \text{ N} \cdot \text{m}^2/\text{kg}^2$
Acceleration due to gravity at the surface of Earth (for the purposes of this examination) .....	$g = 9.80 \text{ m/s}^2$
<b>Earth</b>	
radius .....	$= 6.38 \times 10^6 \text{ m}$
radius of orbit about Sun .....	$= 1.50 \times 10^{11} \text{ m}$
period of rotation .....	$= 8.61 \times 10^4 \text{ s}$
period of revolution about Sun .....	$= 3.16 \times 10^7 \text{ s}$
mass .....	$= 5.98 \times 10^{24} \text{ kg}$
<b>Moon</b>	
radius .....	$= 1.74 \times 10^6 \text{ m}$
radius of orbit about Earth .....	$= 3.84 \times 10^8 \text{ m}$
period of rotation .....	$= 2.36 \times 10^6 \text{ s}$
period of revolution about Earth .....	$= 2.36 \times 10^6 \text{ s}$
mass .....	$= 7.35 \times 10^{22} \text{ kg}$
<b>Sun</b>	
mass .....	$= 1.98 \times 10^{30} \text{ kg}$
Constant in Coulomb's Law .....	$k = 9.00 \times 10^9 \text{ N} \cdot \text{m}^2/\text{C}^2$
Elementary charge .....	$e = 1.60 \times 10^{-19} \text{ C}$
Mass of electron .....	$m_e = 9.11 \times 10^{-31} \text{ kg}$
Mass of proton .....	$m_p = 1.67 \times 10^{-27} \text{ kg}$
Mass of neutron .....	$m_n = 1.68 \times 10^{-27} \text{ kg}$
Permeability of free space .....	$\mu_o = 4\pi \times 10^{-7} \text{ T} \cdot \text{m/A}$
Planck's constant .....	$h = 6.63 \times 10^{-34} \text{ J} \cdot \text{s}$ $h = 4.14 \times 10^{-15} \text{ eV} \cdot \text{s}$
Speed of light .....	$c = 3.00 \times 10^8 \text{ m/s}$
Rydberg's constant .....	$R = 1.097 \times 10^7 \text{ m}^{-1}$
Unified atomic mass unit .....	$u = 1.66 \times 10^{-27} \text{ kg}$
Boltzmann's constant .....	$k = 1.38 \times 10^{-23} \text{ J/K}$
Gas constant .....	$R = 8.31 \text{ J/mol} \cdot \text{K}$
Density of water .....	$= 1.00 \times 10^3 \text{ kg/m}^3$
Density of air .....	$= 1.29 \text{ kg/m}^3$
Standard atmospheric pressure .....	$= 1.01 \times 10^5 \text{ Pa}$
Volume of one mole of gas at STP .....	$= 22.4 \text{ L} (2.24 \times 10^{-2} \text{ m}^3)$
Avogadro's number .....	$N = 6.02 \times 10^{23} \text{ particles/mol}$
Absolute zero .....	$= -273^\circ \text{C}$

**You may detach this page for convenient reference.  
Exercise care when tearing along perforations.**

## TRIGONOMETRIC AND OTHER EQUATIONS

### For Right-angled Triangles:

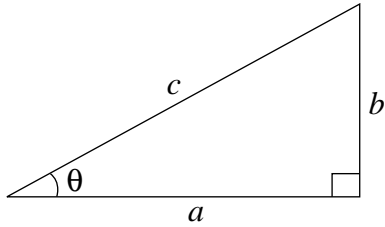

$$a^2 + b^2 = c^2$$

$$\sin \theta = \frac{b}{c} \quad \cos \theta = \frac{a}{c} \quad \tan \theta = \frac{b}{a}$$

$$\text{area} = \frac{1}{2} ab$$

### For All Triangles:

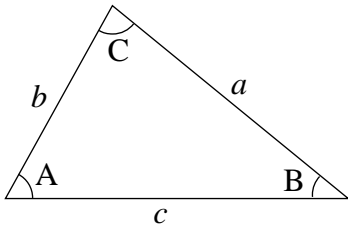

$$\text{area} = \frac{1}{2} \text{base} \times \text{height}$$

$$\sin 2A = 2 \sin A \cos A$$

$$\text{Sine Law: } \frac{\sin A}{a} = \frac{\sin B}{b} = \frac{\sin C}{c}$$

$$\text{Cosine Law: } c^2 = a^2 + b^2 - 2ab \cos C$$

### Circle:

$$\text{Circumference} = 2\pi r$$

$$\text{Area} = \pi r^2$$

### Sphere:

$$\text{Surface area} = 4\pi r^2$$

$$\text{Volume} = \frac{4}{3}\pi r^3$$

### Quadratic Equation:

$$\text{If } ax^2 + bx + c = 0, \text{ then } x = \frac{-b \pm \sqrt{b^2 - 4ac}}{2a}$$

## EQUATIONS

**Note: Vector quantities have not been indicated.**

### 1. Kinematics: (for constant acceleration)

$$v = v_0 + at \qquad v_{av} = \frac{v + v_0}{2} \qquad v^2 = v_0^2 + 2ad$$

$$d = v_0t + \frac{1}{2}at^2$$

### 2. Dynamics:

$$F_f = \mu F_N \qquad F_{net} = ma$$

### 3. Mechanical Energy and Momentum:

$$W = Fd \qquad E_p = mgh \qquad E_k = \frac{1}{2}mv^2$$

$$P = \frac{W}{t} \qquad p = mv \qquad \Delta p = F_{net}\Delta t$$

### 4. Equilibrium:

$$\tau = Fd$$

### 5. Circular Motion and Gravitation:

$$a_c = \frac{v^2}{r} = \frac{4\pi^2r}{T^2} \qquad F = G\frac{m_1m_2}{r^2}$$

$$E_p = -G\frac{m_1m_2}{r} \qquad r^3 \propto T^2$$

### 6. Electrostatics:

$$F = k\frac{Q_1Q_2}{r^2} \qquad E = \frac{V}{d} \qquad V = \frac{kQ}{r}$$

$$E_p = k\frac{Q_1Q_2}{r} \qquad F = QE \qquad V = \frac{\Delta E_p}{Q}$$

### 7. Circuitry:

$$Q = It \qquad V = IR \qquad P = VI$$

**You may detach this page for convenient reference.  
Exercise care when tearing along perforations.**

## EQUATIONS CONTINUED

### 8. Electromagnetism:

$$\begin{array}{lll}
 F = IlB & B = \frac{\mu_0 I}{2\pi d} & \tau = NIAB \\
 F = QvB & B = \mu_0 nI \left( \text{where } n = \frac{N}{l} \right) & \Phi = BA \\
 \mathcal{E} = -N \frac{\Delta\Phi}{\Delta t} & \mathcal{E} = Blv & \frac{V_s}{V_p} = \frac{N_s}{N_p}
 \end{array}$$

### 9. Quantum Mechanics: (Option I)

$$\begin{array}{lll}
 E = hf & c = f\lambda & E_n = (-13.6eV) \frac{Z^2}{n^2} \\
 E_{k_{\max}} = hf - W_0 & \lambda = \frac{h}{p} &
 \end{array}$$

### 10. Fluid Theory: (Option II)

$$\begin{array}{lll}
 \rho = \frac{m}{V} & PV = NkT & PV = \frac{1}{3} Nmv^2 \\
 F = \rho Vg & P = \frac{F}{A} & P = P_G + P_a \\
 PV = nRT & P + \frac{1}{2}\rho v^2 + \rho gh = \text{constant} & E_k = \frac{3}{2}kT \\
 & Av = \text{constant} &
 \end{array}$$

### 11. AC Circuits and Electronics: (Option III)

$$\begin{array}{lll}
 Q = CV & E_p = \frac{1}{2} CV^2 & \tau = RC \\
 X_C = \frac{1}{2\pi fC} & Z = \sqrt{R^2 + (X_L - X_C)^2} & X_L = 2\pi fL \\
 f_0 = \frac{1}{2\pi\sqrt{LC}} & \beta \text{ (current gain)} = \frac{\Delta I_C}{\Delta I_B} & A_f = \frac{A}{1 - \beta A} \\
 & & \text{(where } \beta = \text{ feedback ratio)}
 \end{array}$$

**ROUGH WORK FOR MULTIPLE-CHOICE**

**You may detach this page for convenient reference.  
Exercise care when tearing along perforations.**

## ROUGH WORK FOR MULTIPLE-CHOICE